



optimized  
solutions

# Advanced materials technology profile



advanced materials technology

# THE RANGE



Aerospace



Automotive



Marine Industry



Wind Energy

## high speed 5-axis

## CNC machines for composites and aluminium



Cronus	Technical data	
Linear axes		
X	2500 mm + 20500 mm	85 m/1'
Y	2600 mm + 5000 mm	85 m/1'
Z	1300 mm + 2000 mm	45 m/1'
A	± 110°	24000°/1'
C	± 300°	24000°/1'
5-axes operating units		
Power (S1)	18 kW - 28 kW	
Tool changer magazine	16 + 60 tools	

Poseidon	Technical data	
Linear axes		
X	2500 mm + > 60000 mm	85 m/1'
Y	2600 mm + 10000 mm	85 m/1'
Z	1300 mm + 5300 mm	45 m/1'
(PX5) (KX5)		
B	± 120° + ± 110°	9000°/1'
C	± 270° + ± 300°	9000°/1'
5-axes operating units		
Power (S1)	12 kW + 28 kW	
Tool changer magazine	16 + 60 tools	

Ares	Technical data	
Linear axes		
X	3600 mm + 6000 mm	80 m/1'
Y	1800 mm + 2600 mm	80 m/1'
Z	1200 mm	70 m/1'
B	± 120°	9000°/1'
C	± 270°	9000°/1'
5-axes operating units		
Power (S1)	12 kW - 15 kW	
Tool changer magazine	8 + 32 tools	

# MAIN APPLICATION FIELDS



## solutions to fly high

5-axis CNC machines and flexible tooling for Aerospace



Courtesy of **DAHER-SOCATA**



- Composites milling, trimming and drilling
- Core materials and sandwich panels
- Structural aluminium components
- Aluminium parts from stacked sheets



\* Courtesy of: LOLA Cars International

## we race to make you a winner

hi-tech machines for Automotive and Transportation

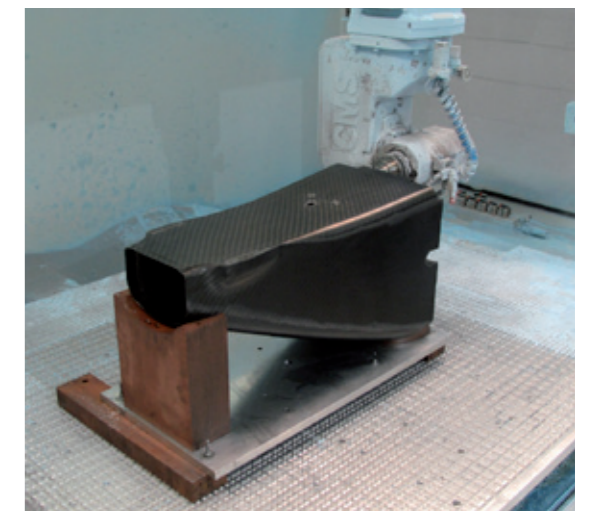
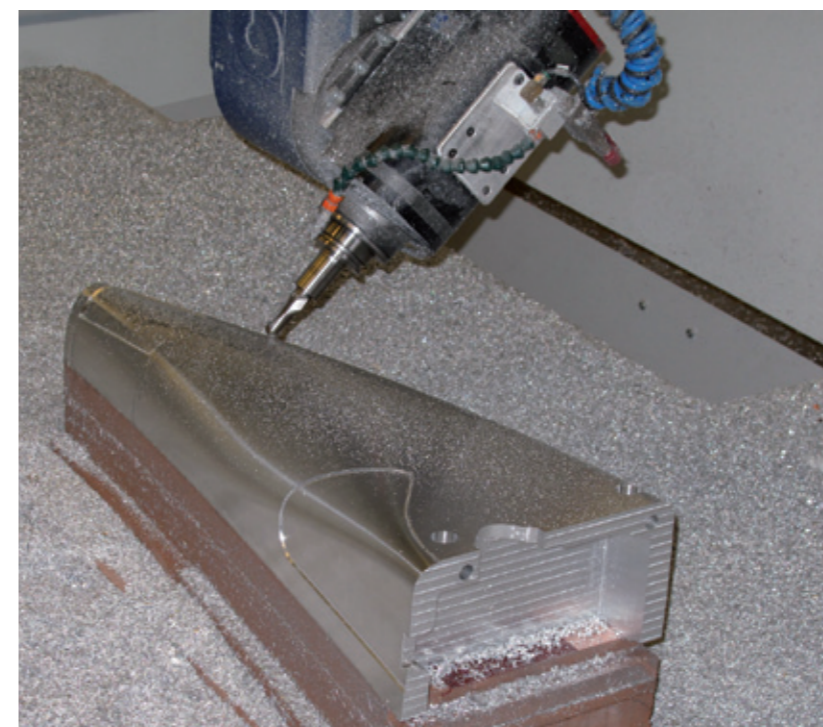

\* Courtesy of: Freeform Technology



- Pattern, styling prototypes
- Parts made in composite materials and aluminium

# MAIN APPLICATION FIELDS



## industrialization in windmill production

5-axis machines for wind energy



## the new wave in boatbuilding

CNC technologies for the marine industry

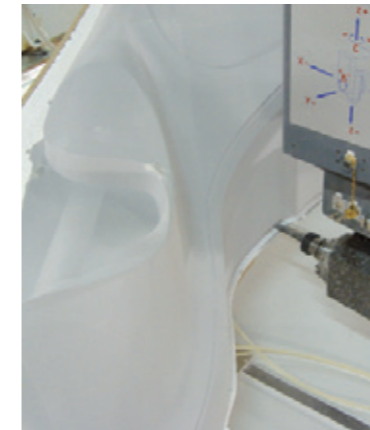
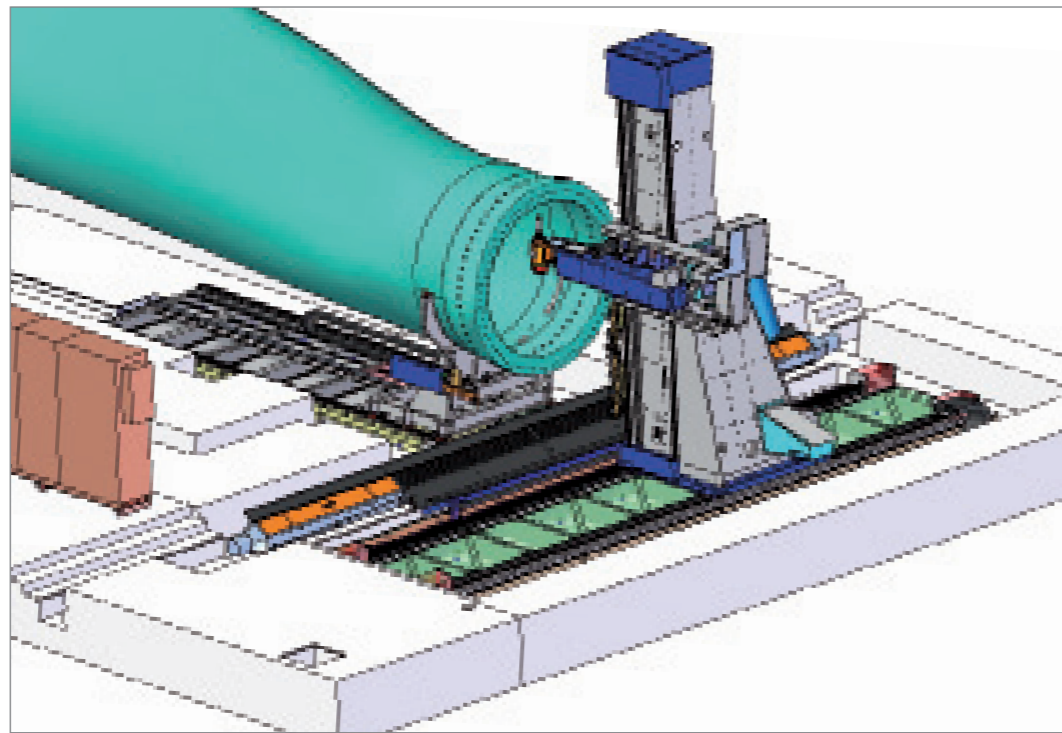
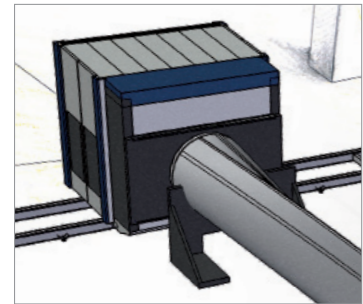

- Plug production
- Drilling and milling of blades and parts

- Plug production
- Glassfiber trimming

# CONVEGNO

# MPA

## THE COMPANY

metodoadv.com

ACCENBS-0512E



Founded in 1969, CMS SpA (Costruzione Macchine Speciali) merged together four companies under the brand CMS Industries which has reached a turnover of 100 millions Euros, with 3 production facilities, 4 subsidiaries and a worldwide sales and service network. CMS Industries is specialized in producing multi-axis CNC machining centers, thermoforming machines, CNC routers and waterjet cutting systems which represent the answer to the high demand of the leading industries in the Aerospace, Automotive, Marine Industry, Wind Energy, Stone, Glass and Wood sectors. This wide products line, joining together quality and precision, offers a comprehensive range of flexible, innovative and cost-effective solutions to cover several production phases or to be customized for specific processes. From 2002 CMS SpA is part of SCM GROUP ([www.scmgroup.com](http://www.scmgroup.com))



[www.cmsindustries.it](http://www.cmsindustries.it)



Technical data are not binding and may be changed by CMS without prior notice.



**CMS S.p.A.**  
**Zogno Plant**  
24019 Zogno (BG) Italy  
Tel. +39.0345.64201  
Fax +39.0345.64280  
[info@cmsindustries.it](mailto:info@cmsindustries.it)

