



# MONOFAST

**UNA SOLUZIONE VINCENTE.  
TUTTO IN POCO SPAZIO.**

A WINNING SOLUTION  
EVERYTHING IN A SMALL  
SPACE.



**CMS Cms**  
wood technology



## UNA SOLUZIONE VINCENTE. TUTTO IN POCO SPAZIO.

A WINNING SOLUTION  
EVERYTHING IN A SMALL SPACE.

**Monofast, l'esclusivo sistema CMS dedicato alla produzione automatizzata di oggetti complessi**

Monofast, CMS exclusive machining system for the automatic processing of complex pieces

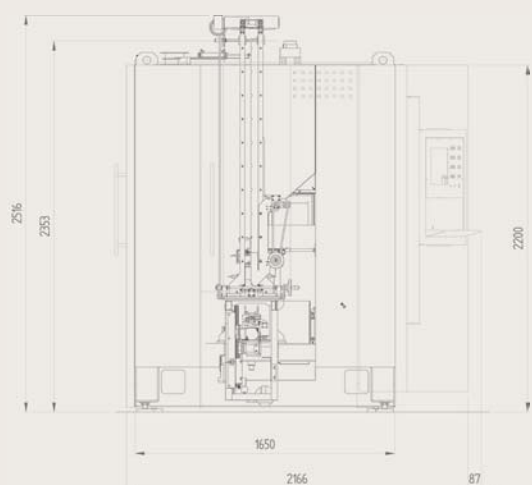
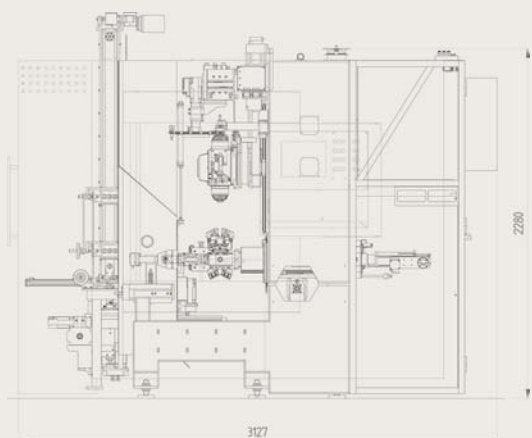

## I vantaggi di Monofast Monofast advantages

- **Lavorazione non presidiata**  
Unmanned operation
- **Cambio utensile in tempo mascherato**  
Tool changing in masked time
- **Elevato grado di automazione con carico e scarico automatico**  
Full automation with automatic loading and unloading
- **Lavorazione delle 6 facce del pezzo**  
Machining of the 6 sides of the piece
- **Massima ergonomia e sicurezza per l'operatore**  
Improved ergonomics and operator's safety
- **Design compatto e funzionale**  
Compact and functional design
- **Pulizia della macchina e dell'ambiente con aspirazione integrata**  
Integrated suction system to keep machine and environment clean

Corsa Assi Axes Stroke	Accelerazione Acceleration (in continuo / in continuous)
X = -240/+360 mm	4 m/s <sup>2</sup>
X = -140/+150 mm	4 m/s <sup>2</sup>
Z = 340 mm	3 m/s <sup>2</sup>
Assi Rotanti Rotating Axes	
V° = -110°/+250°	75 rad/sec <sup>2</sup>
W° = 360° (in continuo / in continuous)	35 rad/sec <sup>2</sup>